

Nuclear Astrophysics II

Lecture 5

Fri. June 1, 2012

Prof. Shawn Bishop, Office 2013,

Ex. 12437

shawn.bishop@ph.tum.de

<http://www.nucastro.ph.tum.de/>

Where to from here?

- We are now at a crossroads for next set of topics:
- Stars with initial mass $M_* > 10$ solar masses end up with the structure on previous page
 - From that point on, the star's fate is sealed: it will become a core collapse supernova
- Stars with initial mass $M_* < 8$ solar masses will not explode
 - They terminate their lives after helium burning is complete and become White Dwarfs
- The remaining topics we have now deal with explosive nuclear burning
- We will begin by looking at the “simplest” explosive objects: Novae

Explosive hydrogen burning: Oxygen-Neon Novae



Planetary nebula are the end-state of a Main Sequence star (think stars that start their lives with a mass less than ~ 8 solar masses). Radiation pressure from the exposed core blows off the outer layers into space. Note: This is *not* an explosive situation.

Star Statistics

- ~ Half of all stars are binary
 - Sun isn't, making it a bit uncommon
- If stars have disparate masses
 - Massive star goes through life much faster, ending as a white dwarf
 - Companion star: finishes Main Sequence, enters Red Giant phase
- Transfer of hydrogen/helium rich material from envelope of RG into gravitational well of WD

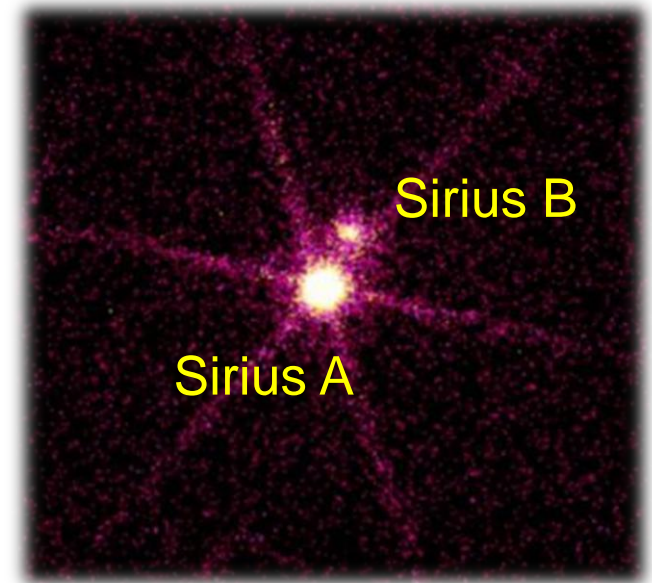

Main Sequence Companion or AGB

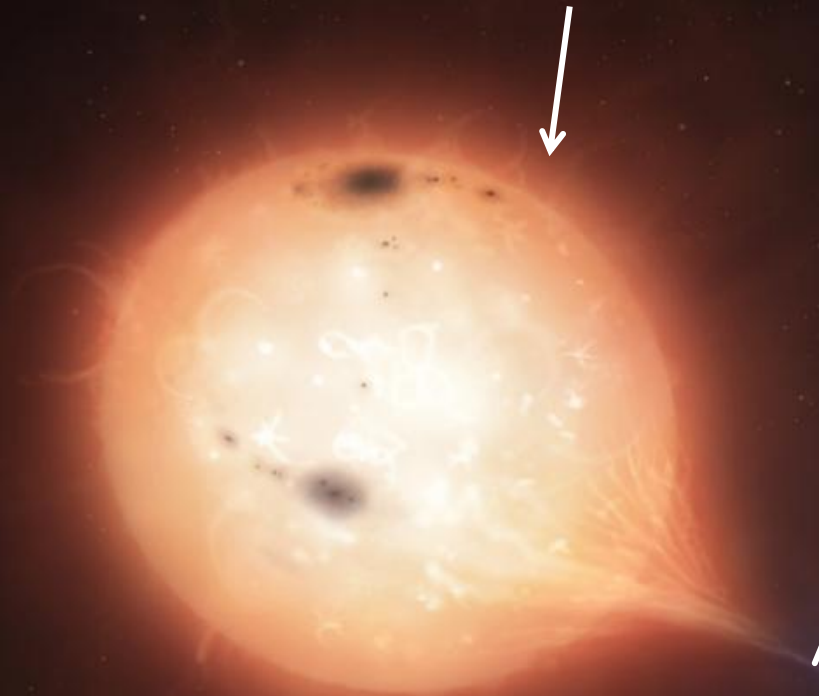

Transfer of H+He-rich (or solar)

Nova Cygni 1992
with HST



WD

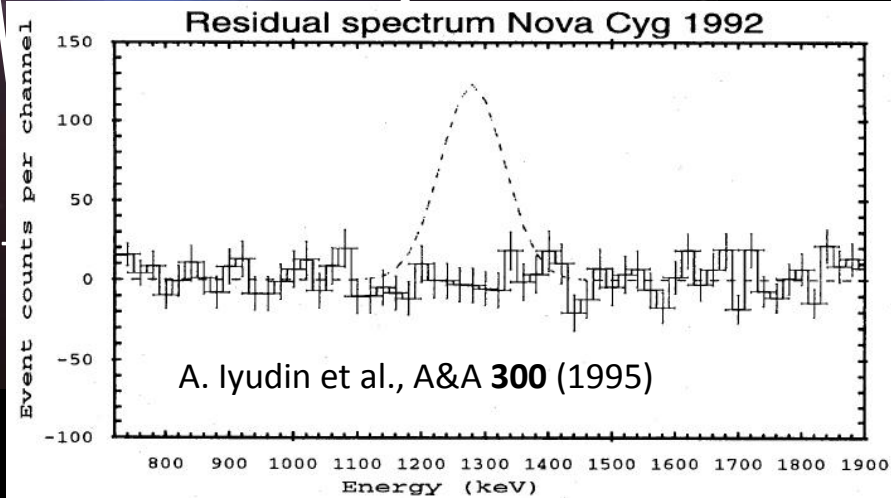

After He-Burning: $^{12}\text{C}:^{16}\text{O} \sim 1:1$

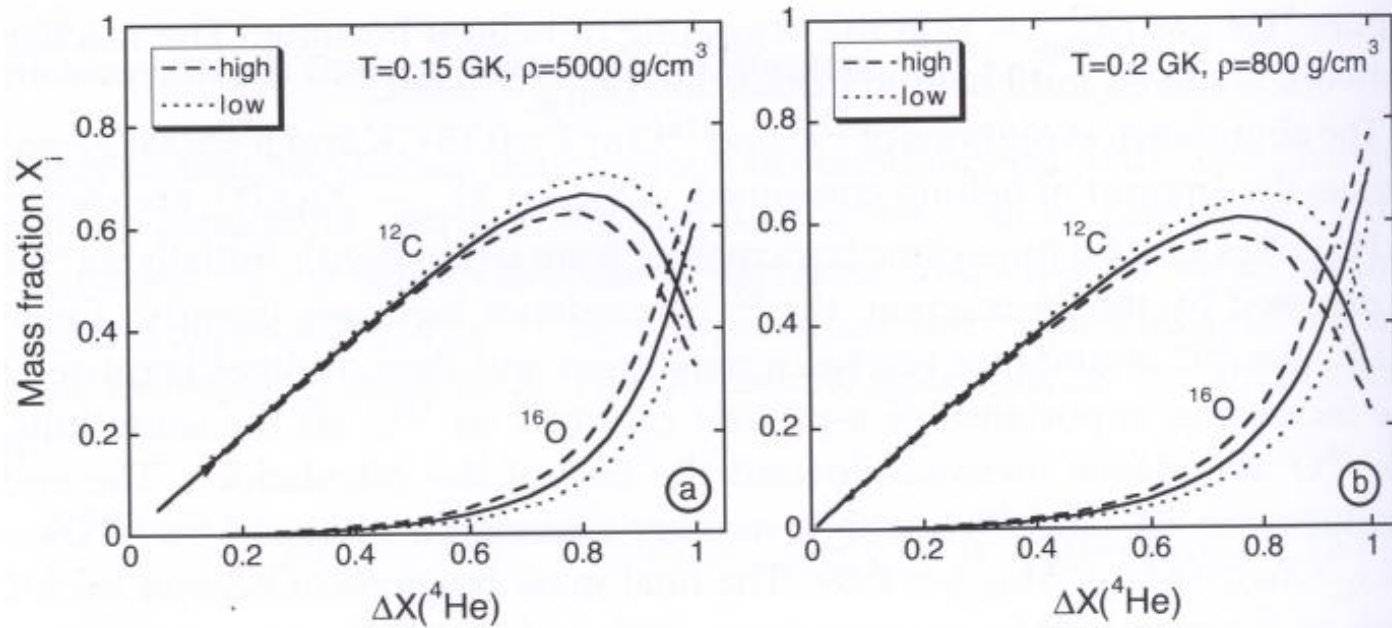

After $^{12}\text{C} + ^{12}\text{C}$ burning:

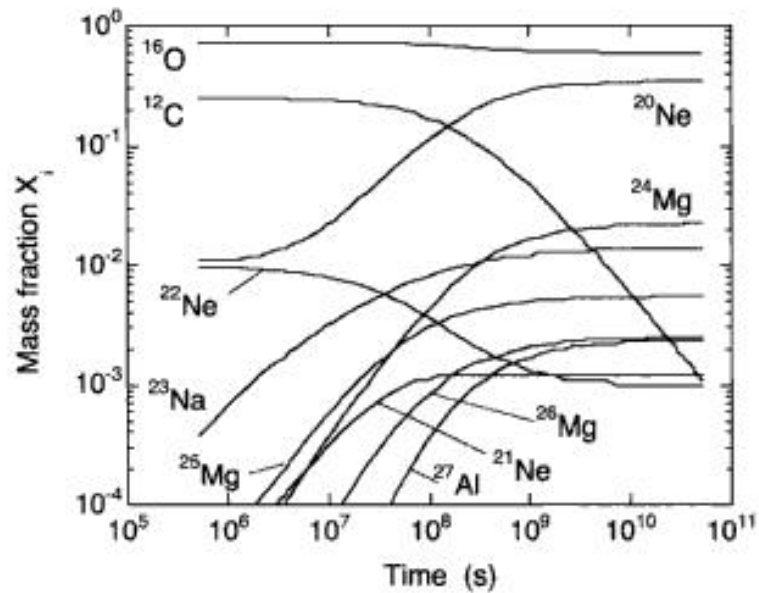

One-Nova Burning Cycles

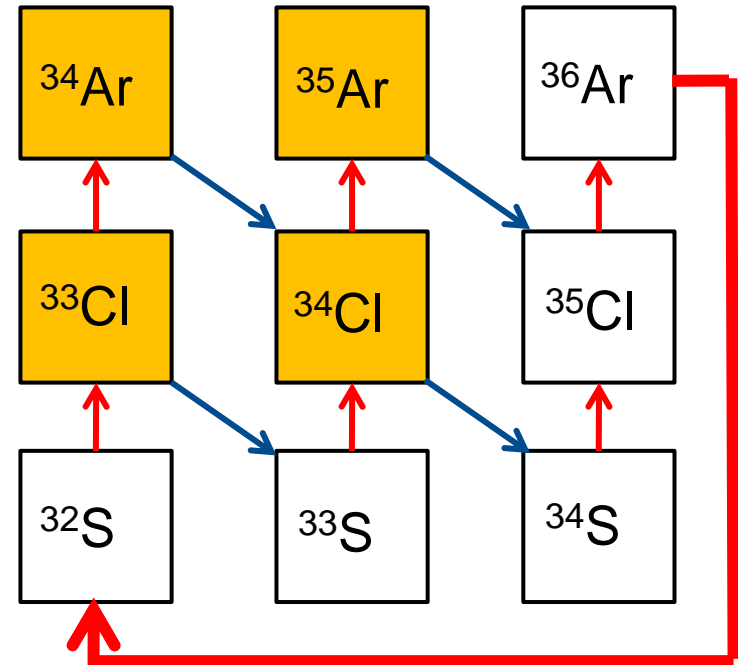
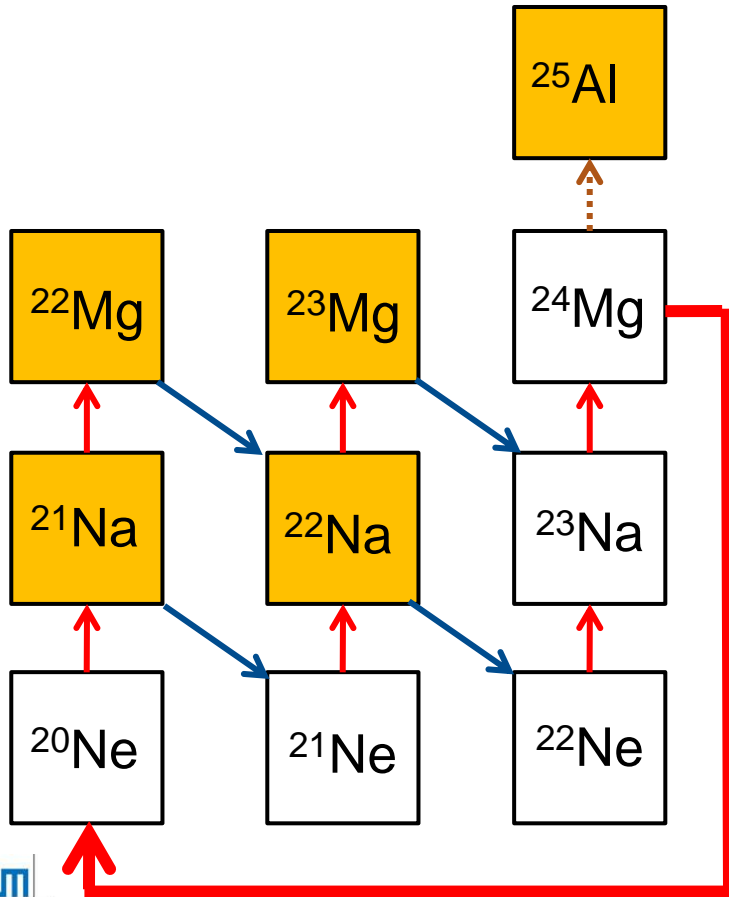

$$Q_{(p,\gamma)} > Q_{(p,\alpha)}$$

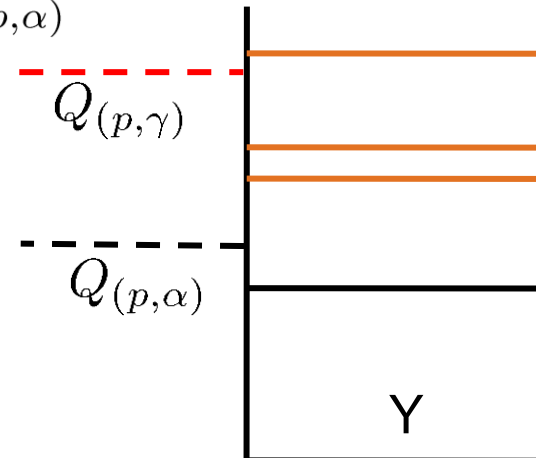

The NaNe Cycle in Explosive Hydrogen Burning

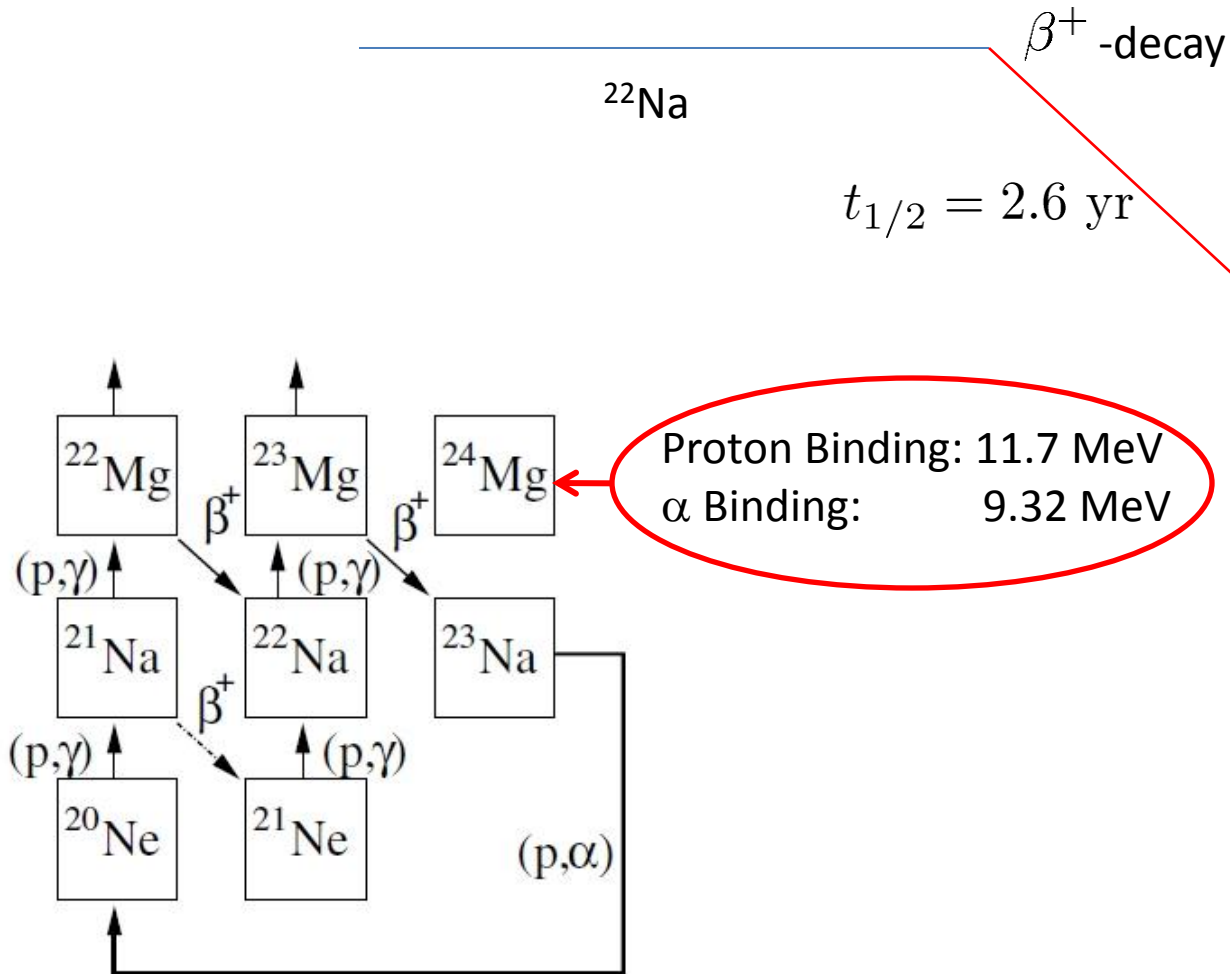

Proton Binding: 11.7 MeV
 α Binding: 9.32 MeV

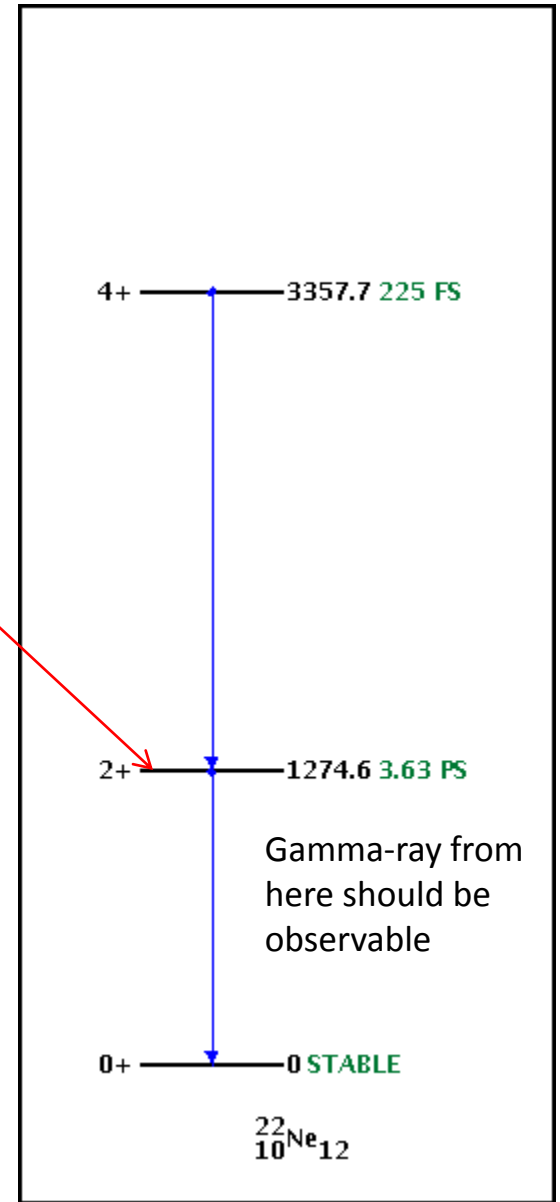

Conditions in the H-rich envelope of different nova models.

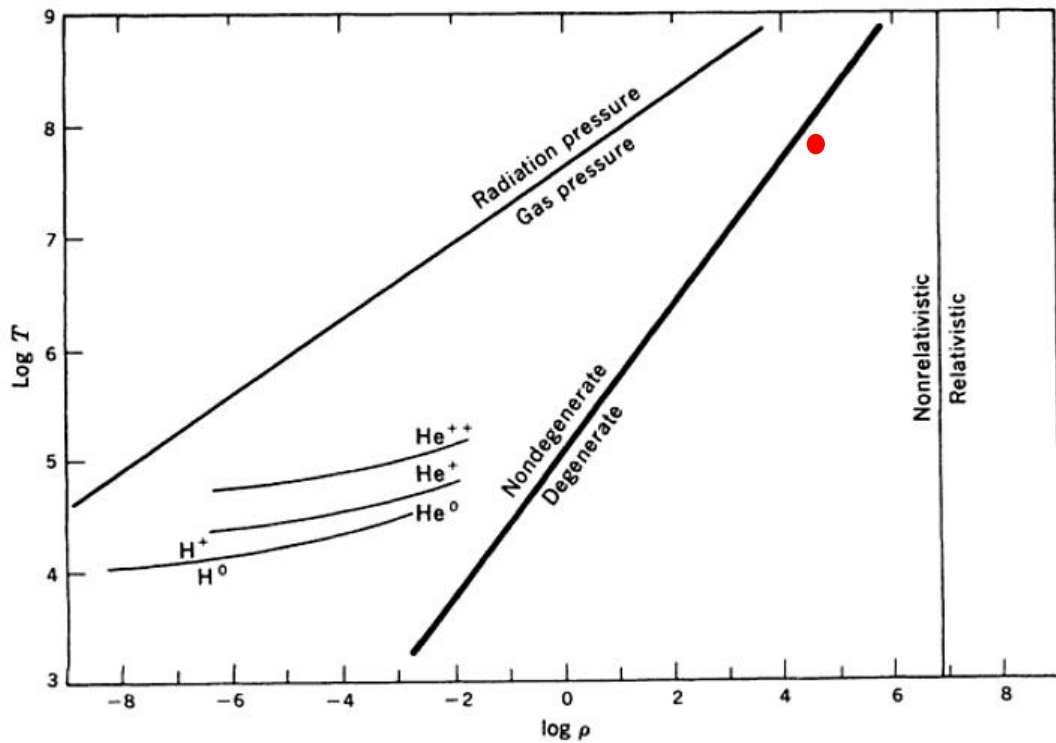
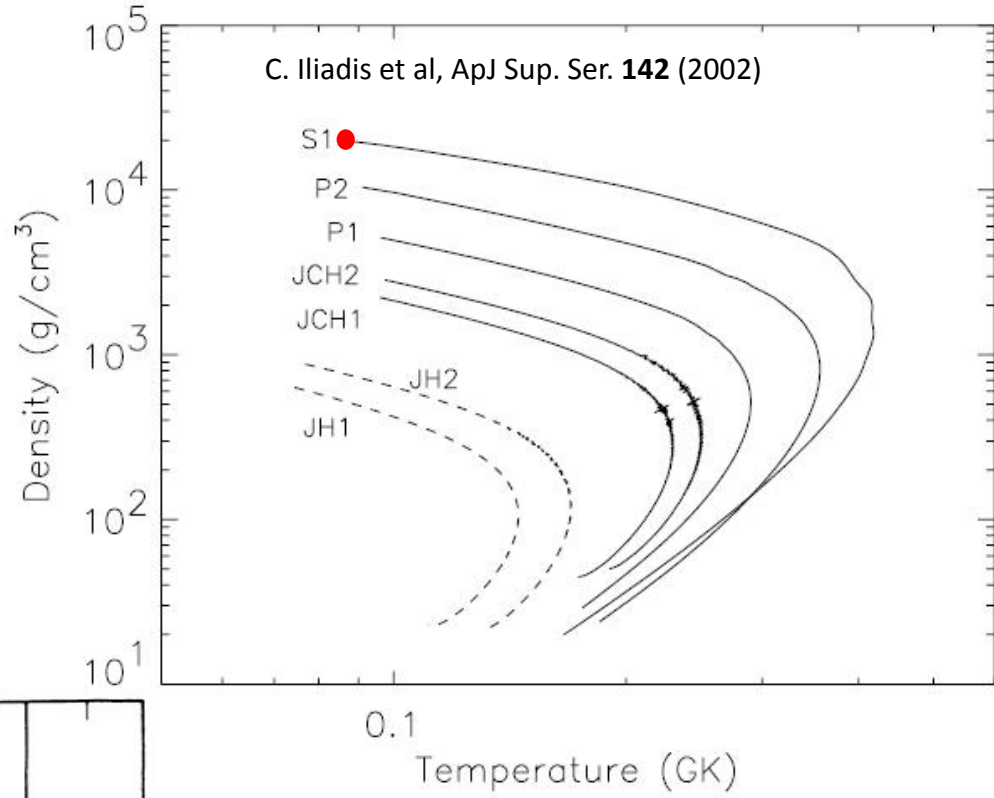

What are the states of importance?

Gamow Window

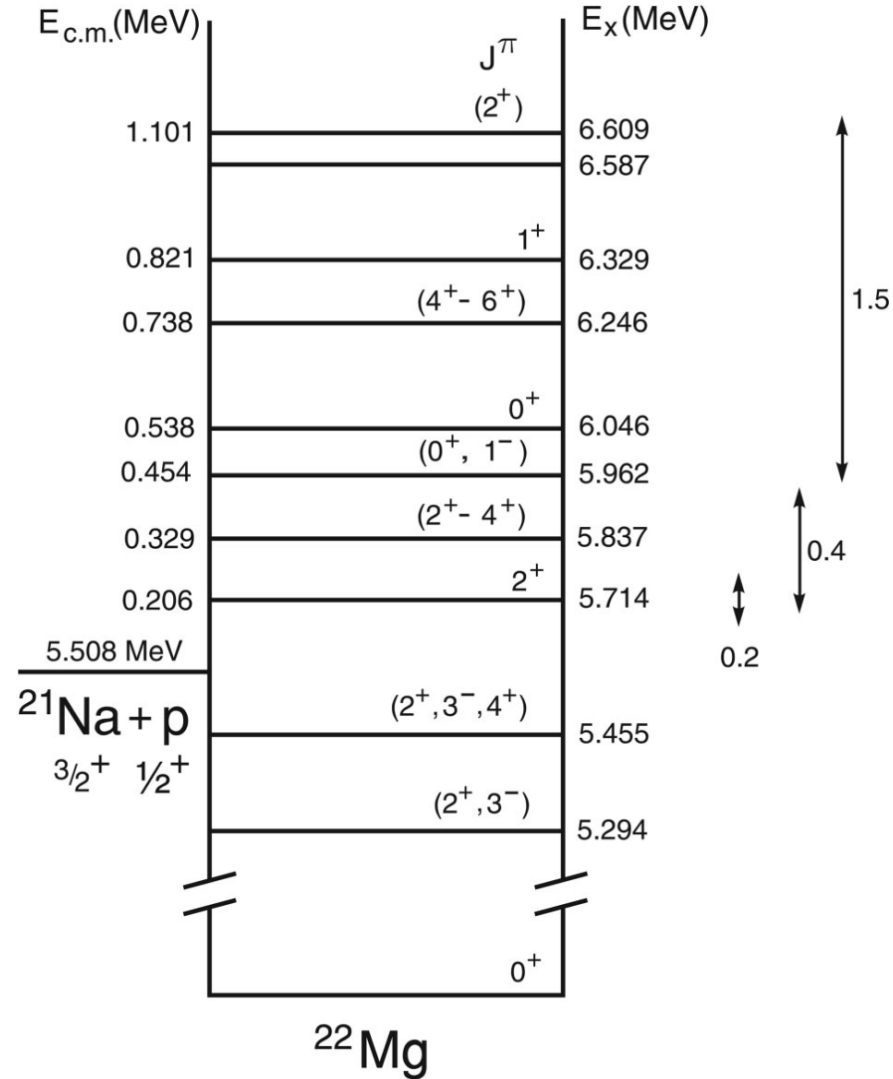
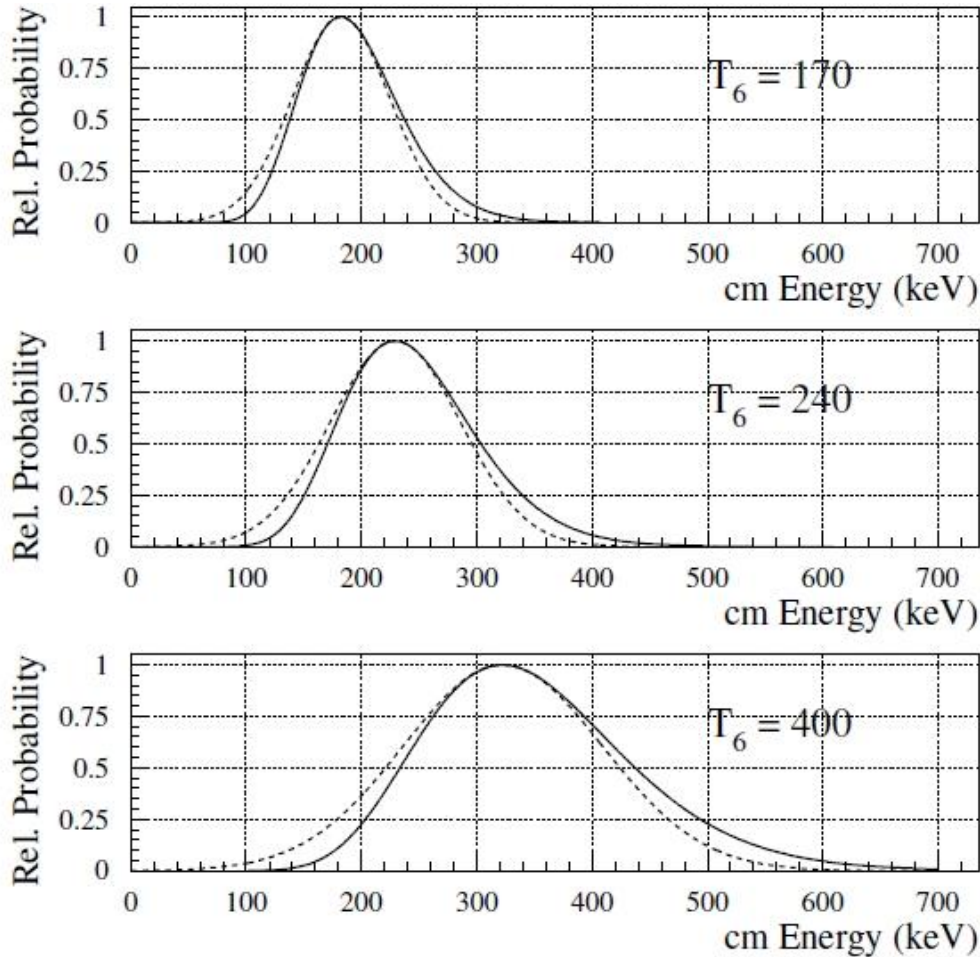

Reminder of Resonant Rate

Our thermonuclear resonant reaction rate is, from page 2, given by:

$$r_{12} = \left(\frac{2\pi}{\mu\tau} \right)^{3/2} \hbar^2 \frac{N_1 N_2}{1 + \delta_{12}} \sum_i (\omega\gamma)_i e^{-E_{r_i}/\tau}$$

where the sum runs over resonant (excited states above proton threshold) in the compound nucleus.

And, the resonance strength is:
$$\omega\gamma \equiv \frac{2J_r + 1}{(2J_1 + 1)(2J_2 + 1)} \frac{\Gamma_p \Gamma_\gamma}{\Gamma}$$

Question: How can we measure $\omega\gamma$, without having to measure the spins J and partial/total widths separately?

In other words, can we create an experiment that lets us measure $\omega\gamma$ itself, directly?

Reaction Yield

Consider: target with number density of target nuclei given by N_t and a thickness of Δx .

The quantity $N_t \Delta x$ can be thought of as being the number of target atoms within a monolayer of target material (units of “atoms/cm²”)

In crossing such a mono-layer, the energy of the beam particles will not change significantly and, moreover, the cross section (a function of energy) will not significantly change. In this mono-layer limit, then, the reaction yield **per incident beam particle** will just be:

$$dY = \sigma N_t \Delta x$$

In general, of course, targets are thicker than a mono-layer, and so the beam energy does change in a finite way, and so will the cross section. Thus, more generally, the reaction yield per incident beam particle is an integral over mono-layers:

$$Y = \int_E^{E-\Delta} N_t \sigma(E) dx$$

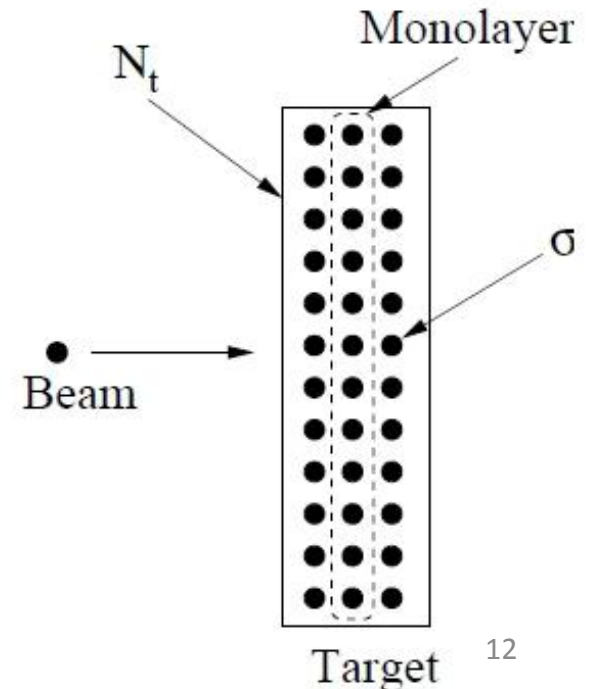

The previous integral has a lower limit corresponding to the beam energy (center of mass units) as it just enters the target, E , and an upper limit of $E - \Delta$ where Δ is the *total* energy loss of the beam particle in the target.

The integral is over the variable x , but the limits are in terms of energy. We need to transform the target thickness into an energy quantity. How?

Charged particles passing through matter lose energy. The amount of energy they lose in a unit length of material depends on their nuclear charge, their instantaneous energy, and the atomic charge of the target nuclei (in first order). There is, therefore, a function called the **stopping power**, ϵ which is defined as the energy loss per mono-layer of target atoms:

$$\epsilon(E_{lab}) = -\frac{1}{N_t} \frac{dE_{lab}}{dx} \quad \text{Lab-frame energy}$$

It is the energy loss per unit length of the incident particle in the target material. It is a *measured* quantity. The yield function is now:

$$Y = \frac{m_p + m_t}{m_t} \int_{E-\Delta}^E \frac{\sigma(E)}{\epsilon(E)} dE \qquad E_{cm} = \frac{m_t}{m_b + m_t} E_{lab}$$

Recall the Breit-Wigner cross section we derived in Lecture 8

$$\sigma(E) = \frac{\pi \hbar^2}{2\mu E} \frac{2J_r + 1}{(2J_p + 1)(2J_t + 1)} \frac{\Gamma_p \Gamma_\gamma}{(E - E_r)^2 + \Gamma^2/4}$$

For proton, gamma and total widths considered as constants, and when the total resonance width $\Gamma \ll \Delta$ (narrow resonance, like a delta-function), then the above function can be integrated.

$$Y = \frac{\pi \hbar^2}{2\mu E_r} \frac{m_t}{m_b + m_t} \frac{2J_r + 1}{(2J_p + 1)(2J_t + 1)} \frac{\Gamma_p \Gamma_\gamma}{\Gamma} \epsilon^{-1} \times$$

$$\left[\arctan \left(\frac{E - \Delta}{\Gamma/2} \right) - \arctan \left(\frac{E - E_r - \Delta}{\Gamma/2} \right) \right]$$

This is the *thick target yield curve*. It has a maximum at $E = E_r + \Delta/2$. Exercise: confirm this. At maximum, the yield is:

$$Y_{max} = \frac{\pi \hbar^2}{2\mu E_r} \frac{m_t}{m_b + m_t} \omega \gamma \epsilon^{-1} \arctan \left(\frac{\Delta}{\Gamma} \right)$$

And, as per our conditions on previous page, when $\Gamma \ll \Delta$ then:

$$Y_{max} = \frac{\pi \hbar^2}{2\mu E_r} \frac{m_t}{m_b + m_t} \omega \gamma \epsilon^{-1} \arctan \left(\frac{\Delta}{\Gamma} \right)$$

$$Y_{max} = \frac{\pi^2 \hbar^2}{4\mu E_r} \frac{m_t}{m_b + m_t} \omega \gamma \epsilon^{-1}$$

So:

Once we know the resonance energies of compound nucleus, and the stopping power in the target (can be measured), we can obtain the resonance strength from the maximum of the thick target yield curve.

Thick Target Yield Curve

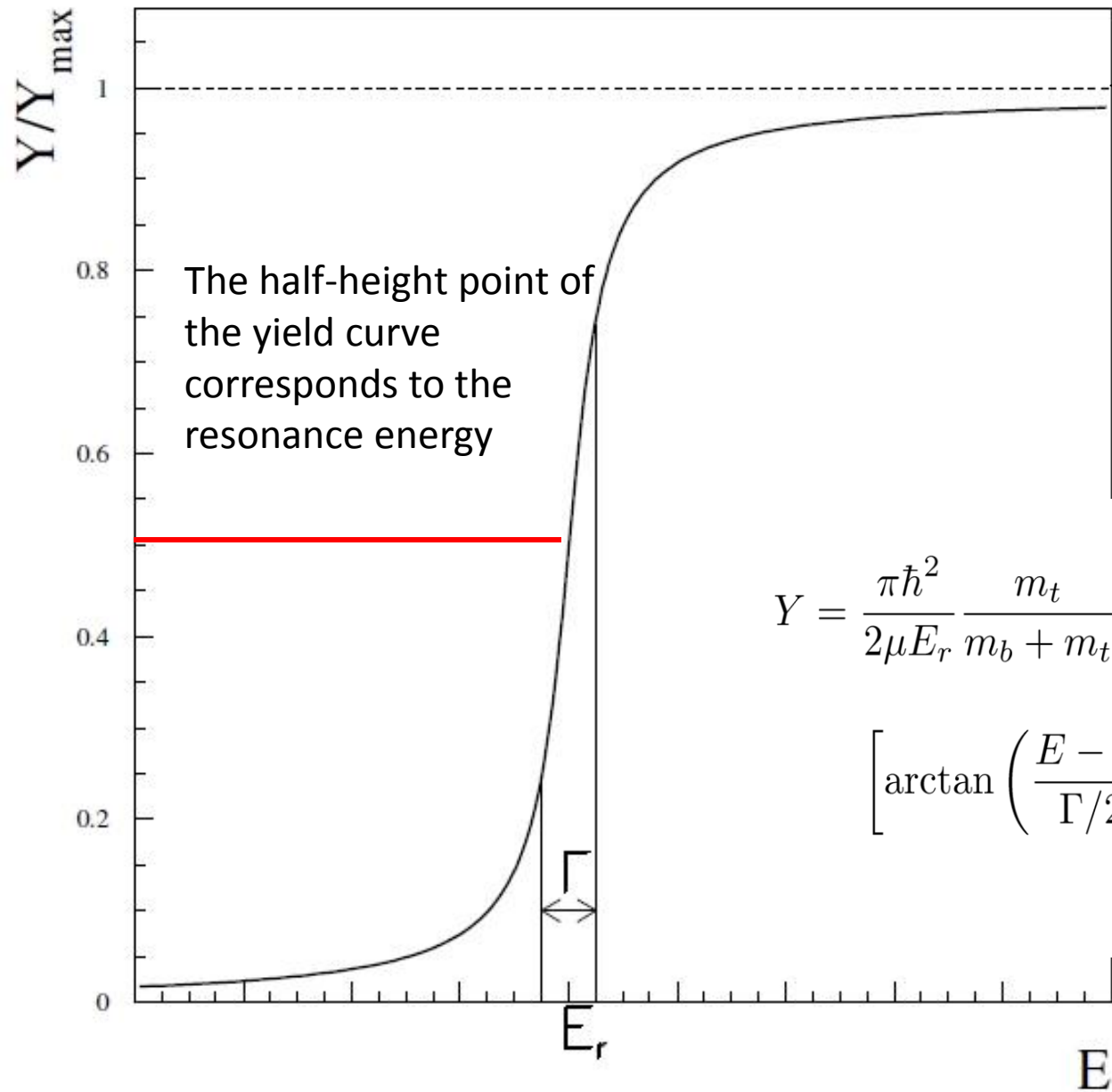

The half-height point of the yield curve corresponds to the resonance energy

$$Y_{max} = \frac{\pi^2 \hbar^2}{4\mu E_r} \frac{m_t}{m_b + m_t} \omega \gamma \epsilon^{-1}$$

$$Y = \frac{\pi \hbar^2}{2\mu E_r} \frac{m_t}{m_b + m_t} \frac{2J_r + 1}{(2J_p + 1)(2J_t + 1)} \frac{\Gamma_p \Gamma_\gamma}{\Gamma} \epsilon^{-1} \times \left[\arctan \left(\frac{E - \Delta}{\Gamma/2} \right) - \arctan \left(\frac{E - E_r - \Delta}{\Gamma/2} \right) \right]$$

Measuring a Resonance Strength with a Radioactive Ion Beam

EXPERIMENTAL APPROACH

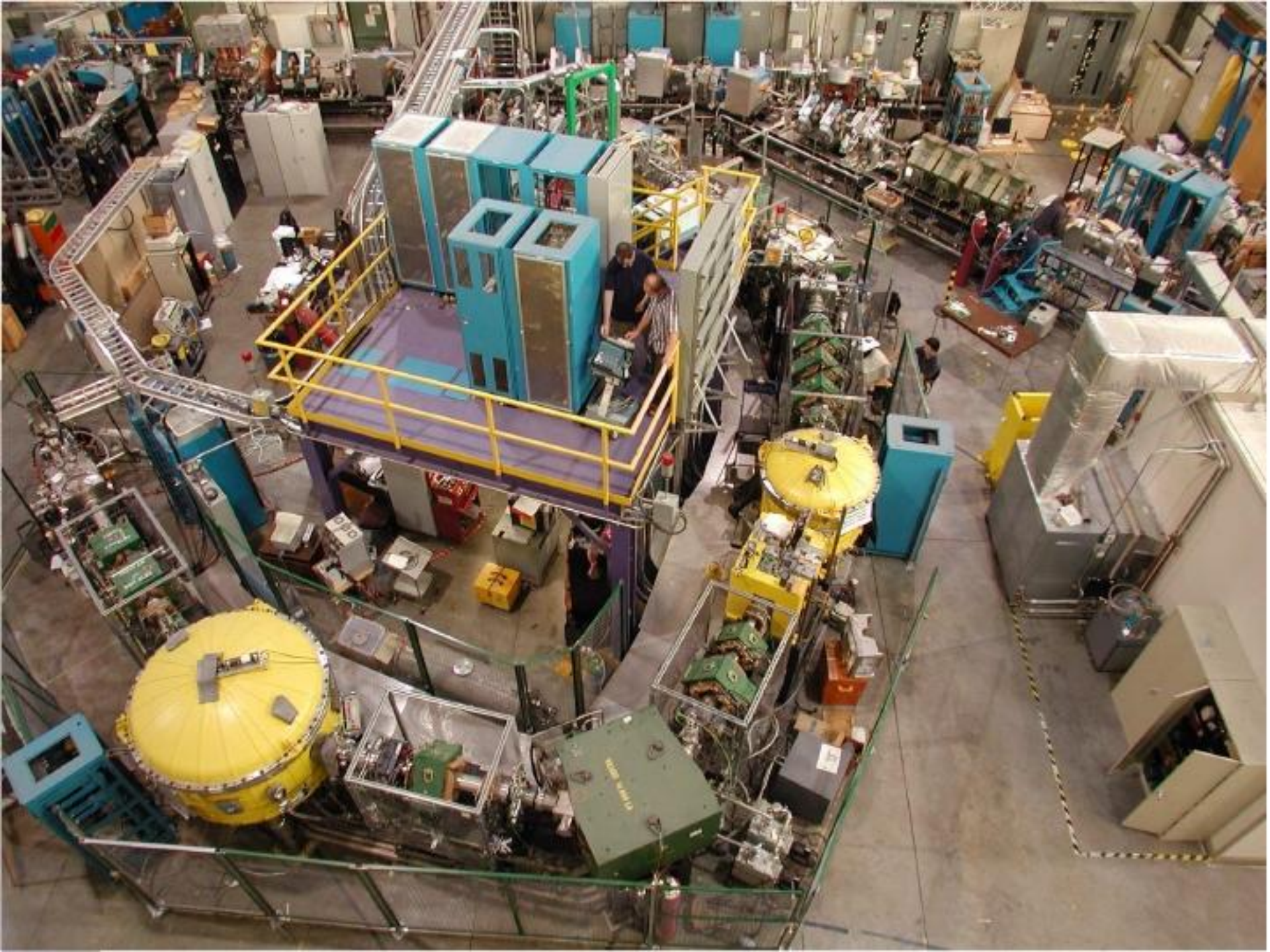

Kinematics of the reaction we are studying:

$^{22}\text{Mg}^*$ = Mg nucleus in an excited (nuclear) state.

^{22}Mg = Mg nucleus in ground state (after de-excitation)

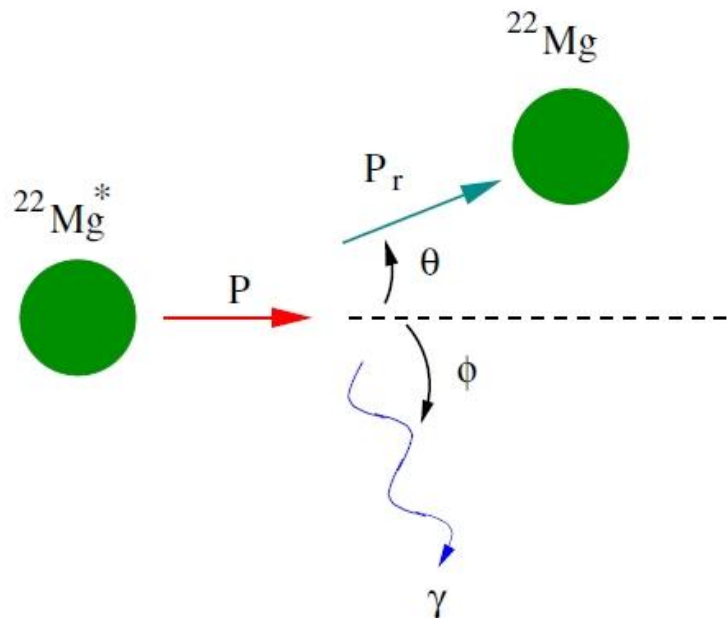

Momentum conservation:

$$p_{beam} = p = \sqrt{2m_b T_b} = p^*$$

Recoil angle θ as a function of γ -ray emission angle is:

$$\theta = \arctan \left[\frac{\sin \phi}{\frac{\sqrt{2m_b T_b}}{E_\gamma/c} - \cos \phi} \right]$$

Maximized when $\phi = \pi/2$

When γ -ray angle is 90° , the recoil angle will also be maximum. This limits the angular acceptance of the spectrometer, and we can use this result to determine the limits of the energy acceptance.

Gas Target Chamber:

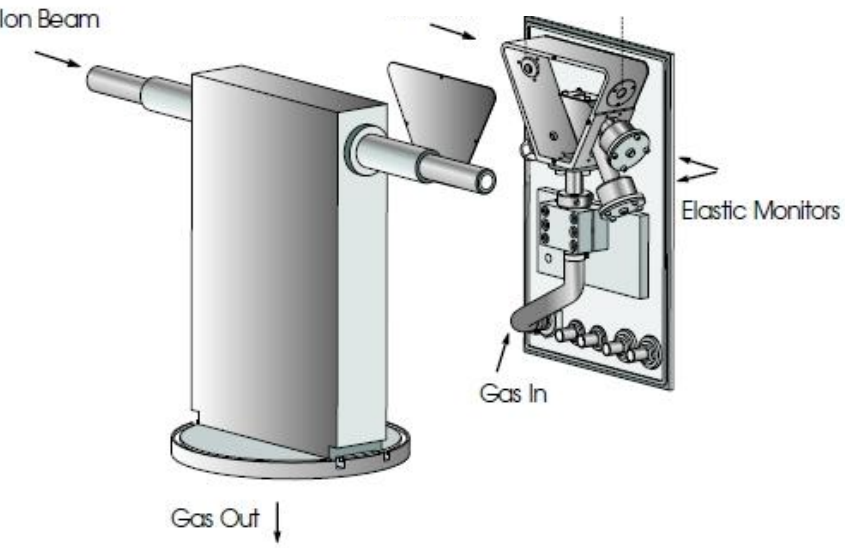
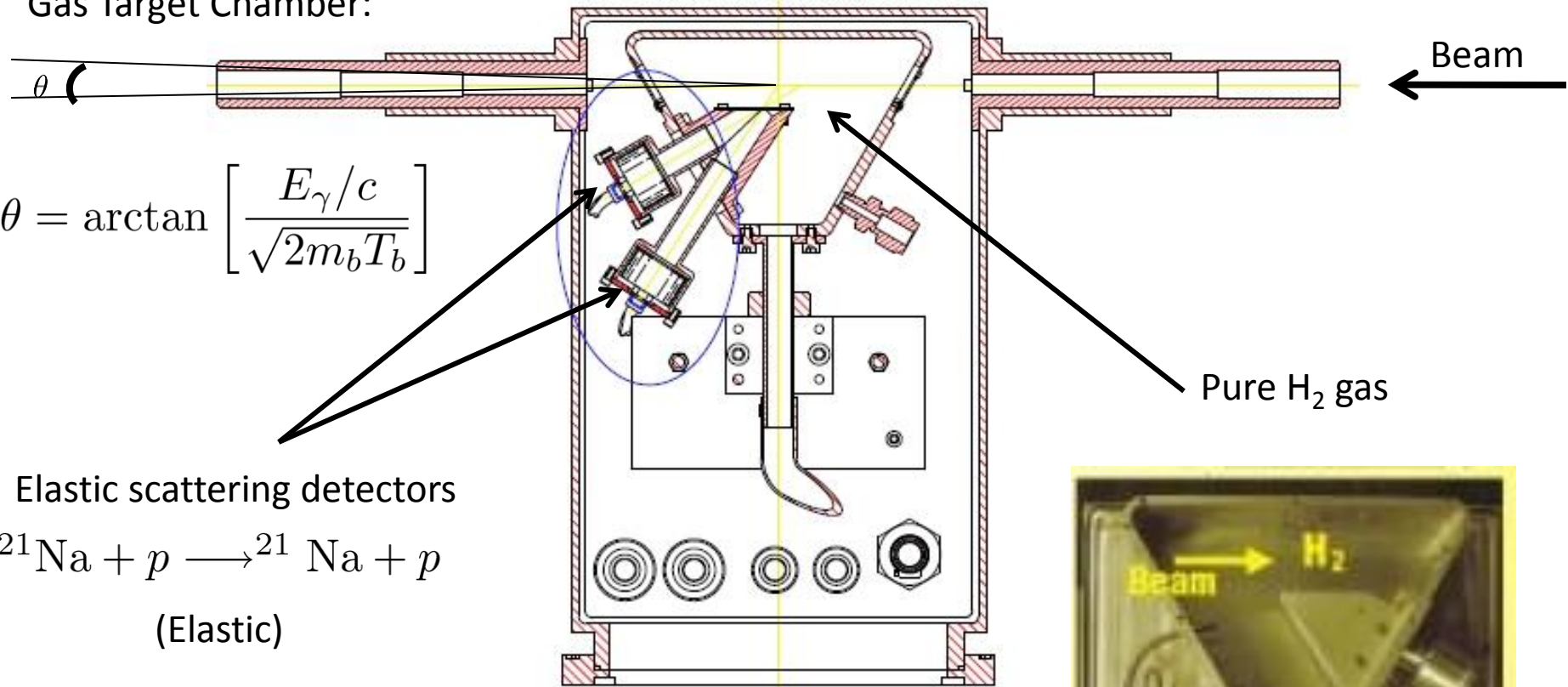

Gamma-Detector Array Surrounding Gas Target

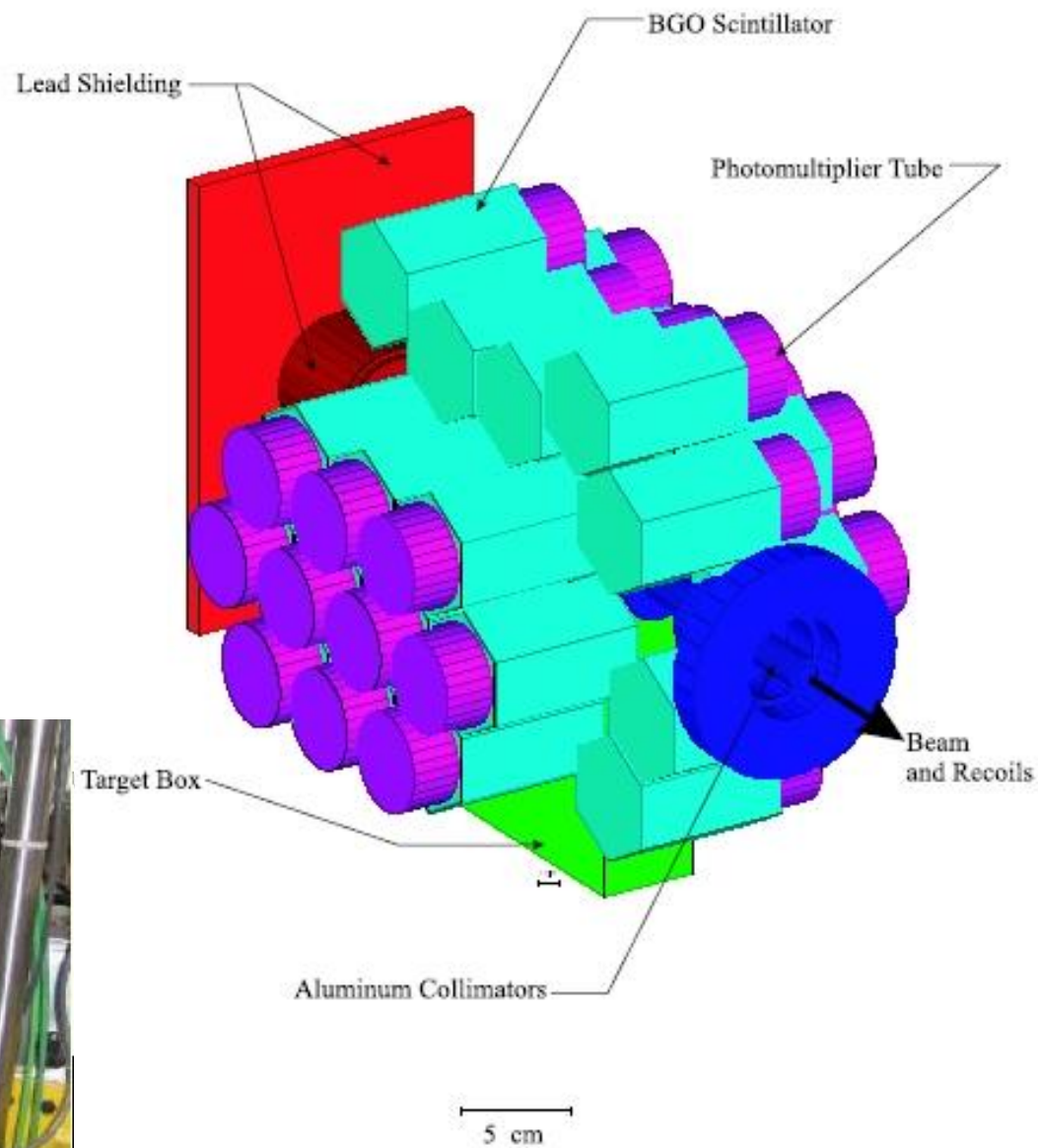
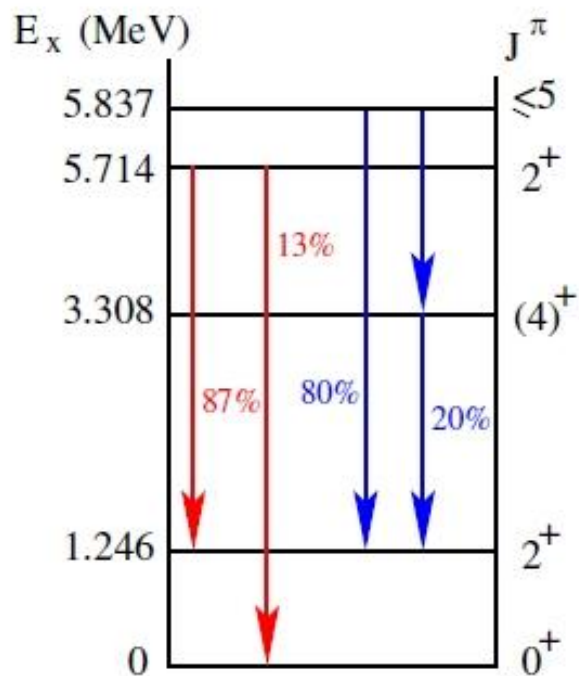

It is clear that, for γ -ray emission collinear with the incident beam axis, the recoil nucleus will have maximum (minimum) kinetic energy for backward (forward) emission.

Therefore, the maximum/minimum momentum of the fusion recoils is given by:

$$p_r = p^* \pm p_\gamma = \sqrt{2m_b T_b} \left(1 \pm \frac{E_\gamma}{\sqrt{2m_b T_b}} \right)$$

Square both sides, and divide by $2m_r$ for the max/min recoil kinetic energy

$$T_r = \frac{m_b}{m_r} T_b \left(1 \pm \frac{2E_\gamma/c}{\sqrt{2m_b T_b}} + \frac{E_\gamma^2/c^2}{2m_b T_b} \right)$$

Around a few %

Order 10^{-4}

This result, written in this form, shows us that the fusion recoil particles will have max/min kinetic energies \sim several percent different from that of the unreacted beam particles.

How do we use these facts to separate the unreacted beam from the fusion particles?

DRAGON Layout

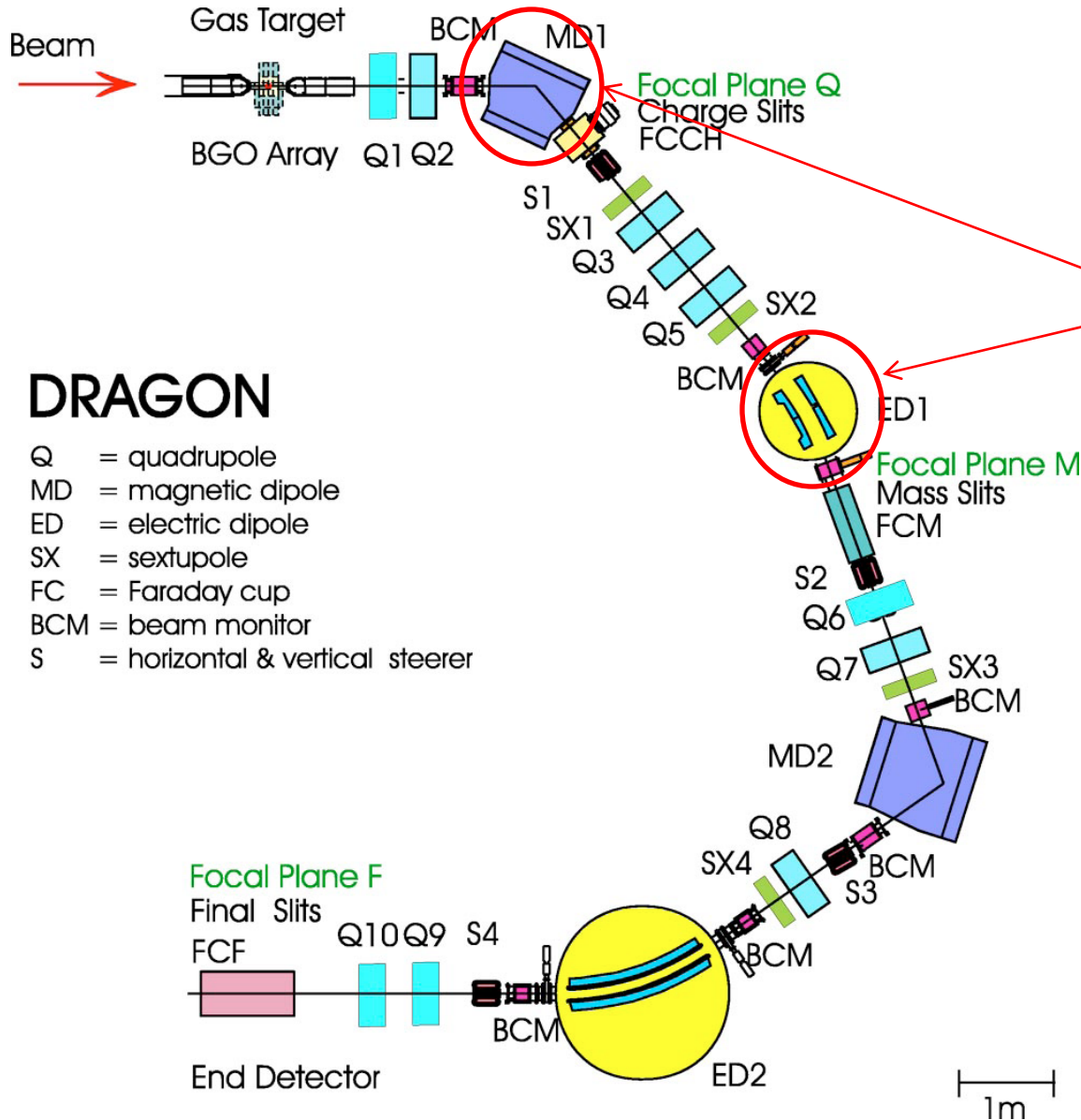

DRAGON

- Q = quadrupole
- MD = magnetic dipole
- ED = electric dipole
- SX = sextupole
- FC = Faraday cup
- BCM = beam monitor
- S = horizontal & vertical steerer

This is a “recoil mass separator. It’s design is optimized to filter out unreacted beam particles and to allow the fusion products to be transported through the system for final detection in the “End Detector” at the end of the apparatus.

The devices that perform the filtering are the Magnetic Dipoles (MD) and Electrostatic Dipoles (ED).

Reactions in the target conserve momentum → beam particle momentum = fusion recoil momentum.

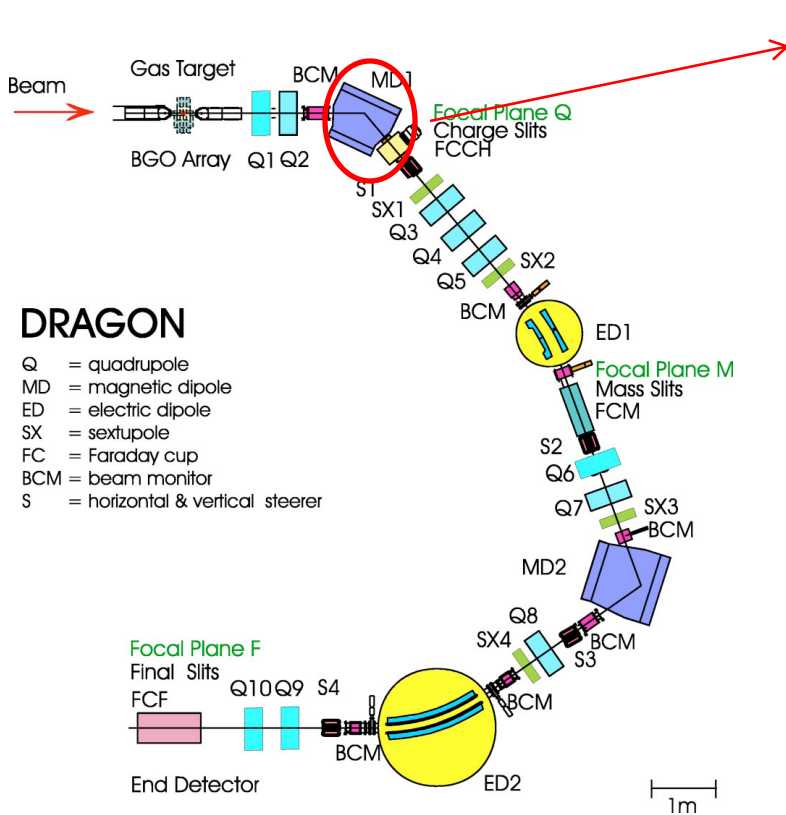

DRAGON

- Q = quadrupole
- MD = magnetic dipole
- ED = electric dipole
- SX = sextupole
- FC = Faraday cup
- BCM = beam monitor
- S = horizontal & vertical steerer

Dipole magnet works on principle of Lorentz force. (ρ = bending radius)

$$\mathbf{F} = q\mathbf{v} \times \mathbf{B} = qvB = m \frac{v^2}{\rho}$$

(circular trajectory)

$$\Rightarrow p = qB\rho$$

For fixed B-field and fixed bending radius, the MD transport particles on the basis of their magnetic rigidity, p/q .

Exiting the target, the beam and fusion recoils have same p . Also, some fraction of beam and recoils will have the same charge states.

→ Mag. Dipole will **not** separate beam and fusion recoils. It will allow both to pass through, but the momentum and charge state of each will be **known**.

Once we have selected particles of known p/q , we must find a way to try to separate out the beam particles from the fusion recoils. We do this with Electric Dipole benders.

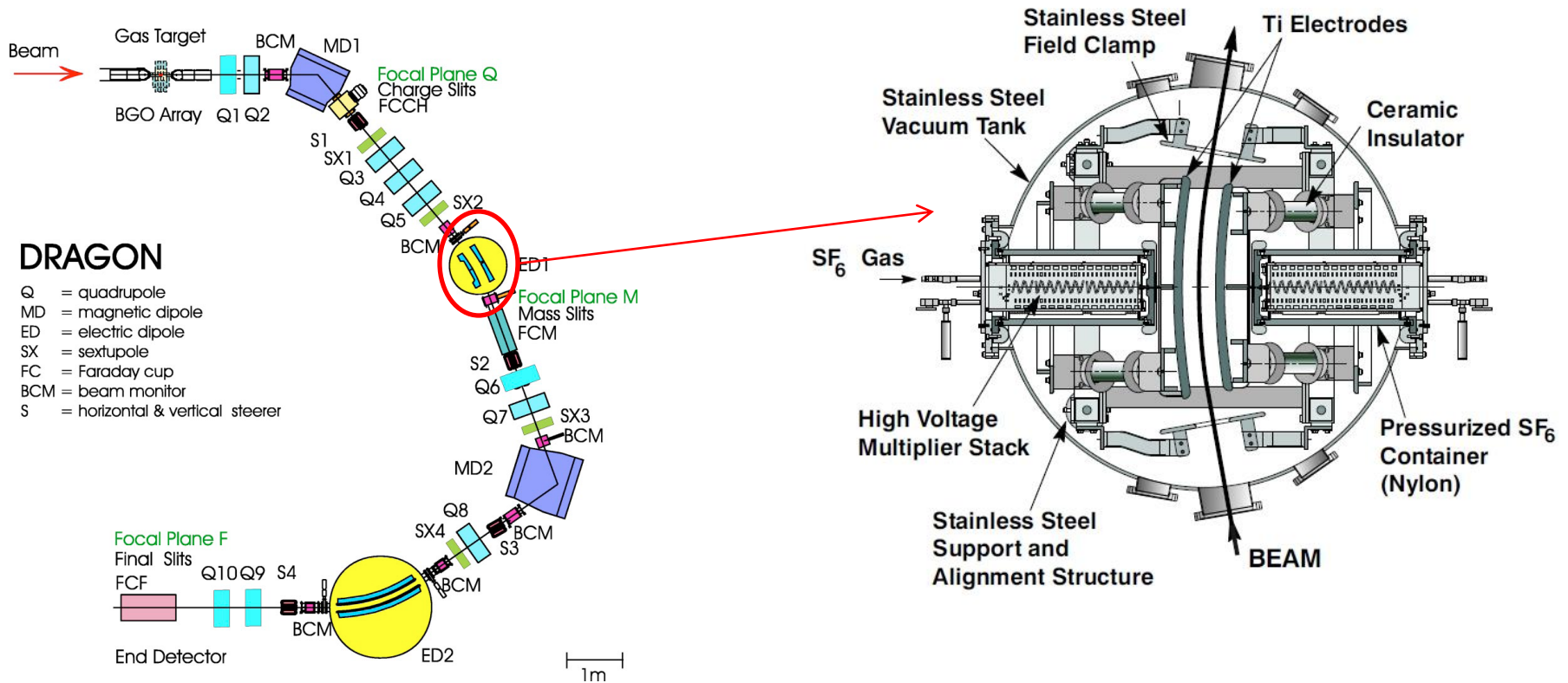

Deflection of charged particles along circular trajectories of radius R . Electric field \mathcal{E} .

$$q\mathcal{E} = m \frac{v^2}{R} \Rightarrow T = \frac{q\mathcal{E}R}{2}$$

It is at the ED where the kinetic energy difference between fusion recoil and beam particle is exploited for separating unreacted beam from the fusion events!

A sense of Scale. This is the smaller of the two Electric Dipole Benders. Bending radius is 2.0 meters. The larger ED has a bending radius of 2.5 meters.



Charged Particle Transport Through the Mass Separator

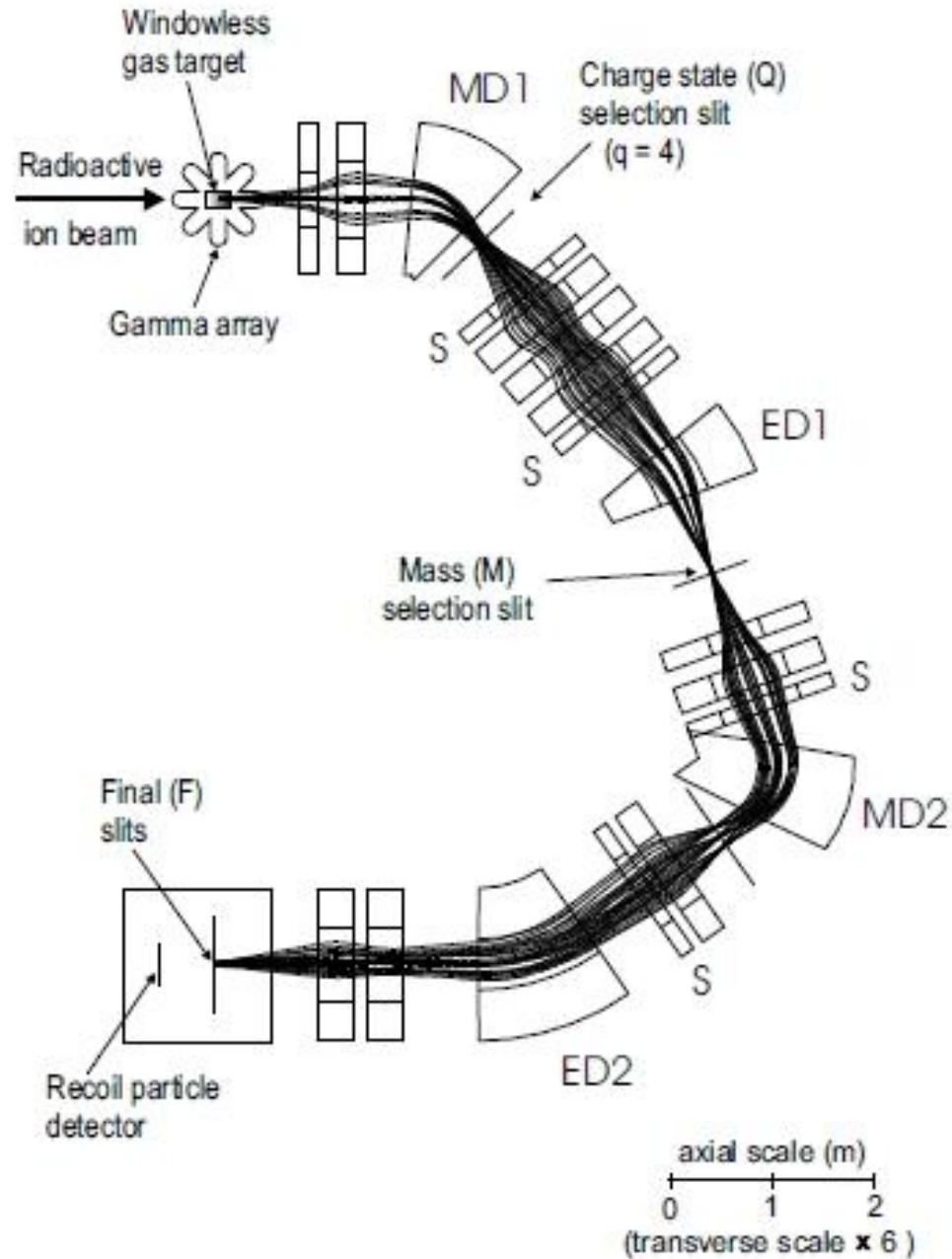

DRAGON Facility at TRIUMF, Canada
Detector of Recoils & Gamma-rays Of Nuclear reactions

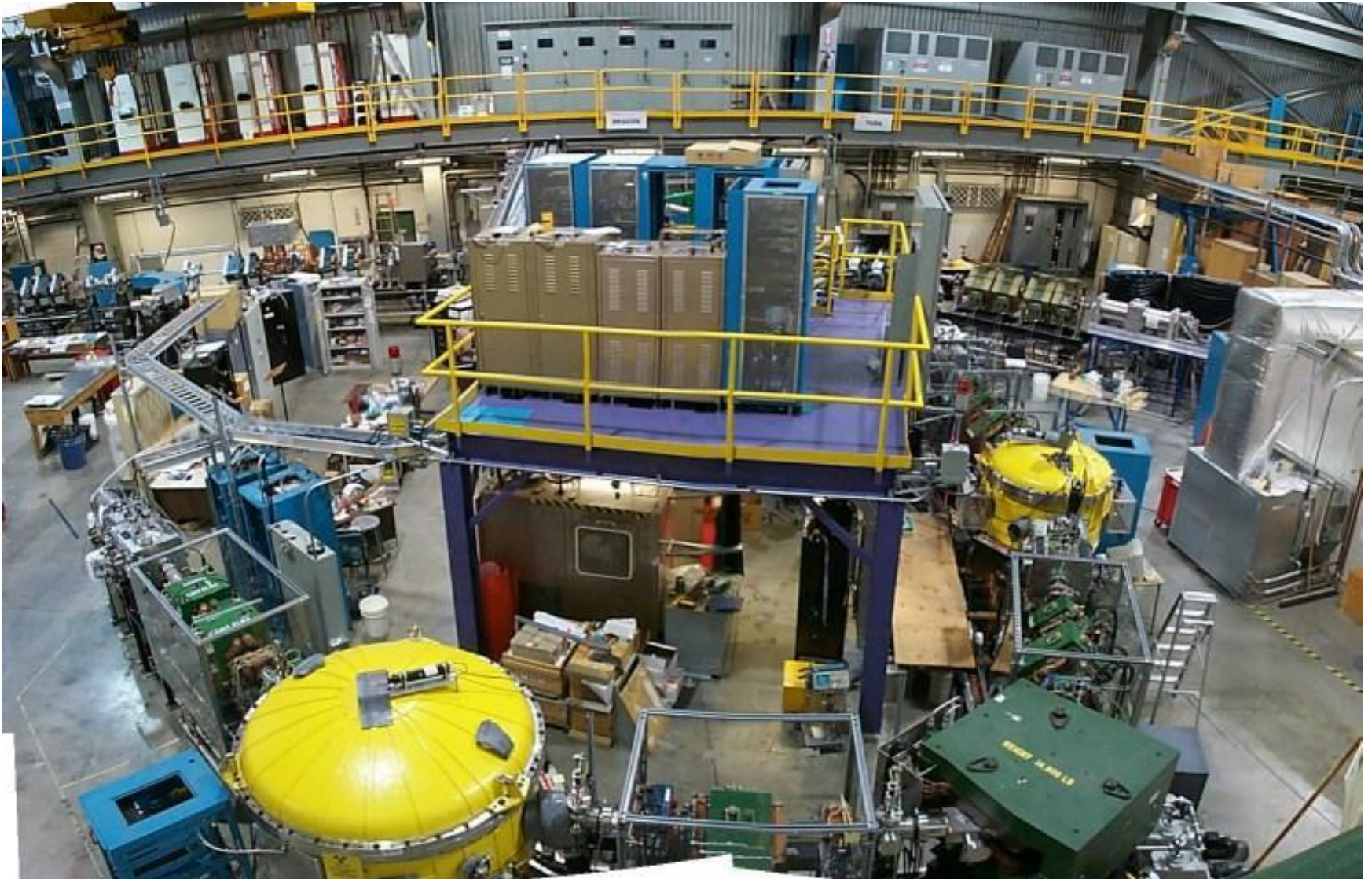

Selection of the data, extraction of the $^{21}\text{(p,}\gamma\text{)}^{22}\text{Mg}$ reaction rate, and the impact for ^{22}Na production

EXPERIMENTAL RESULTS

Time of Flight and Gamma-ray Spectra for ^{21}Na Beam energy of 215 keV/A

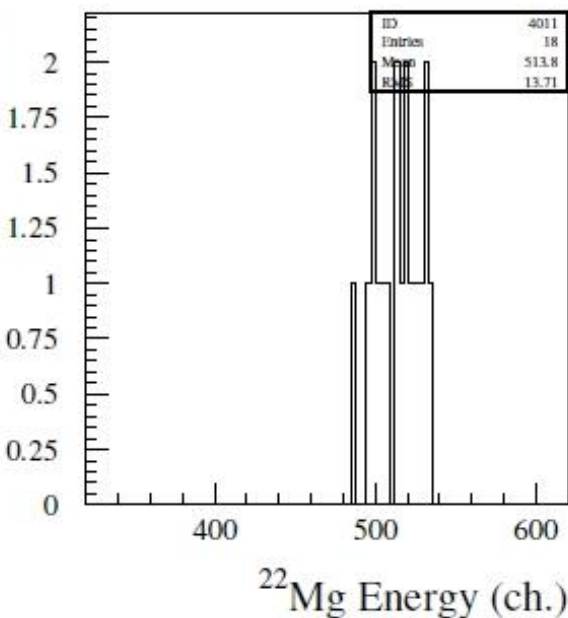
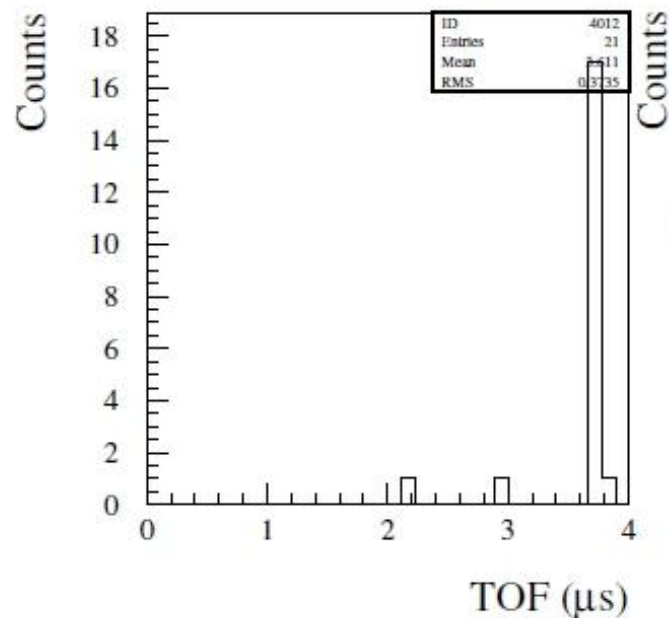
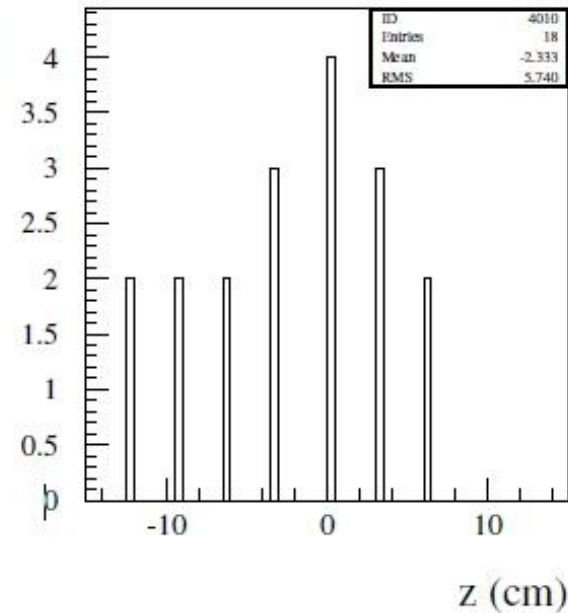
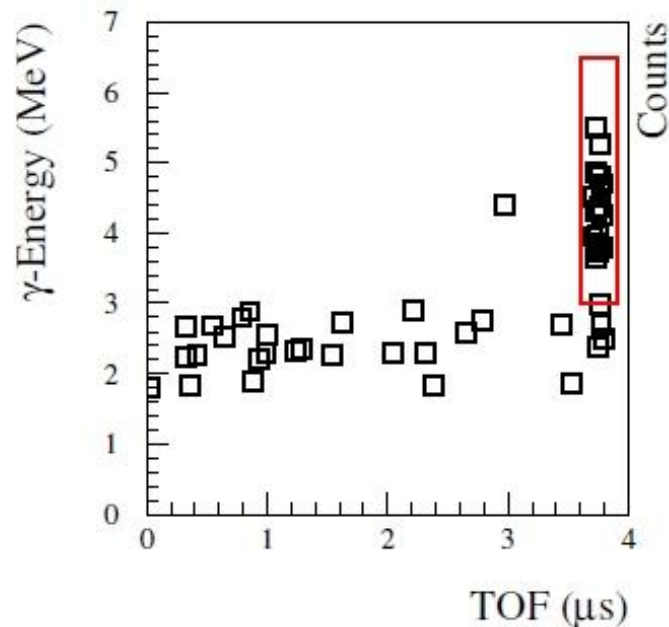
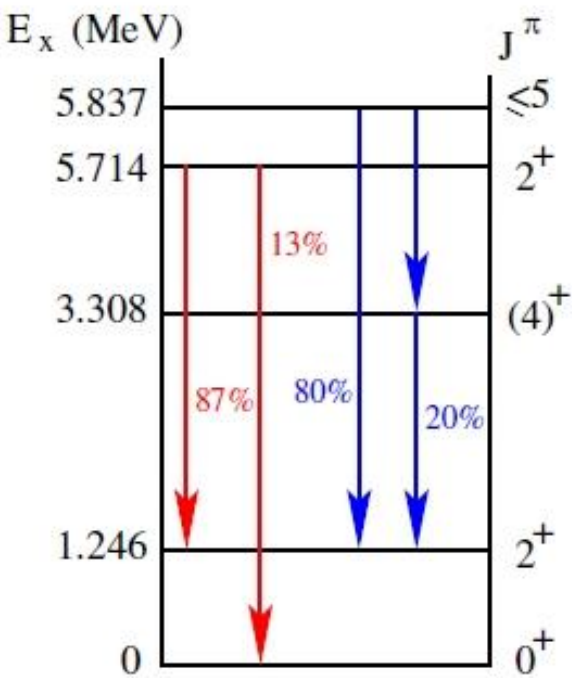

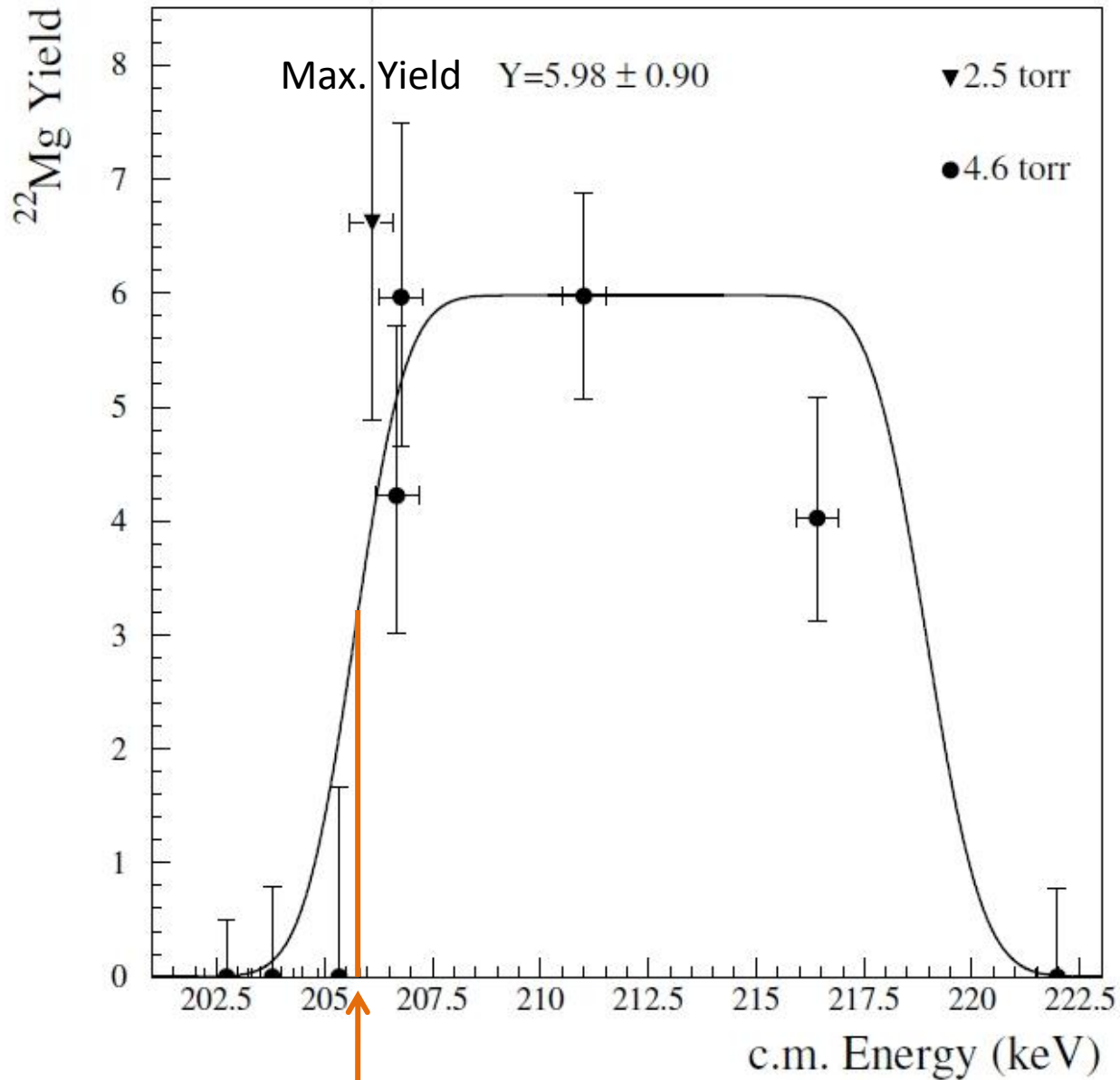
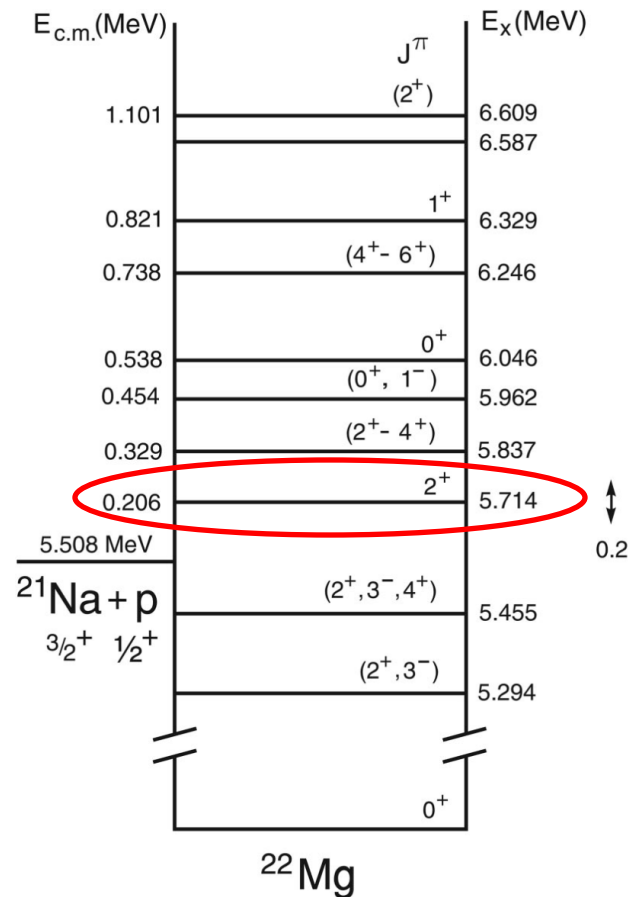

Reaction Rate for the two lowest energy Resonances in ^{22}Mg

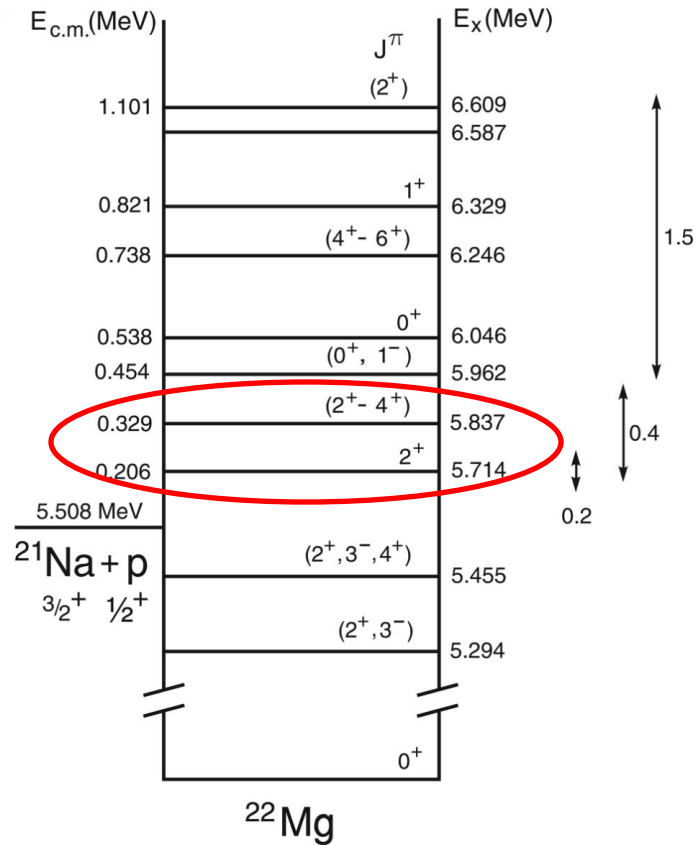
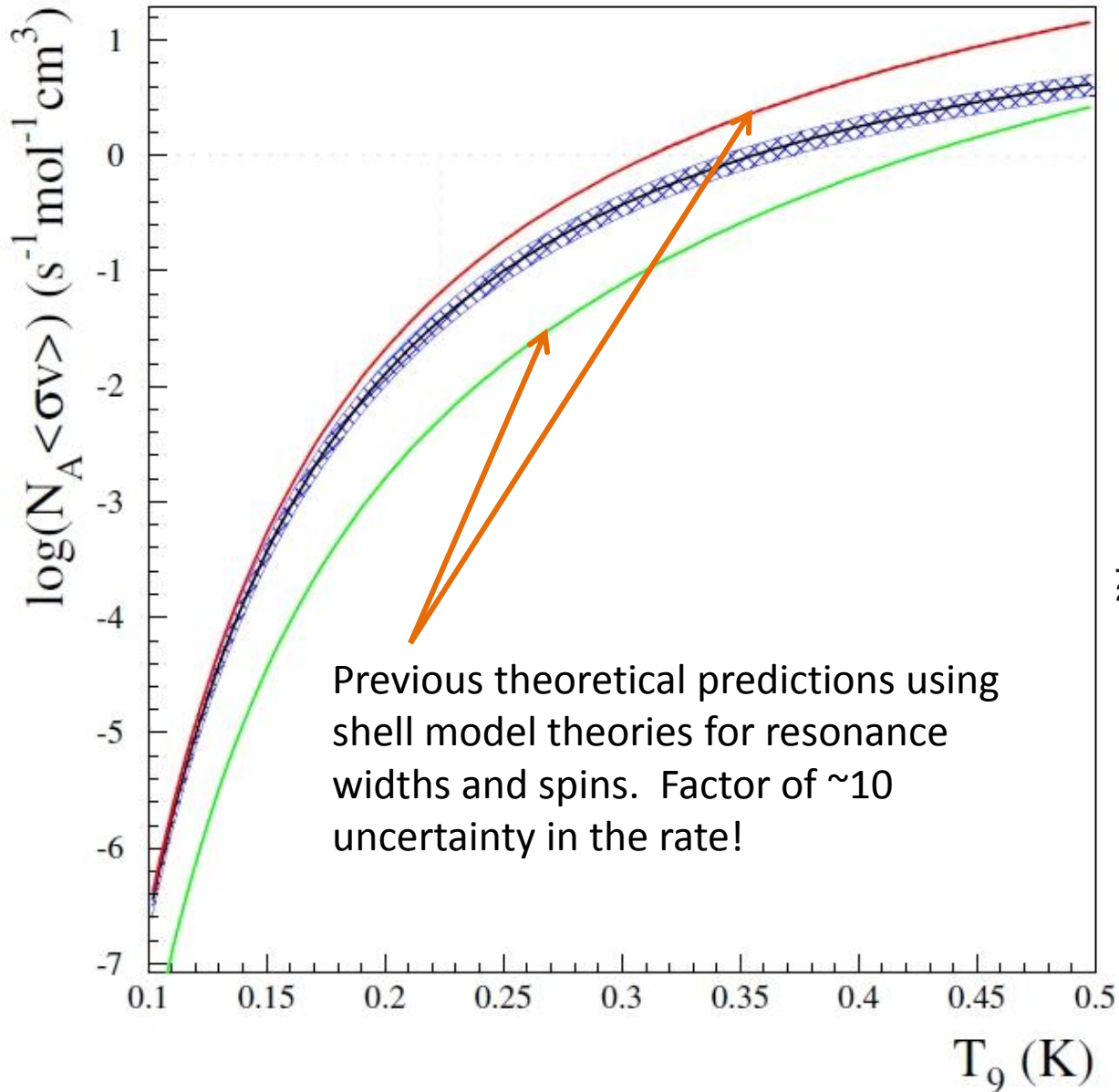

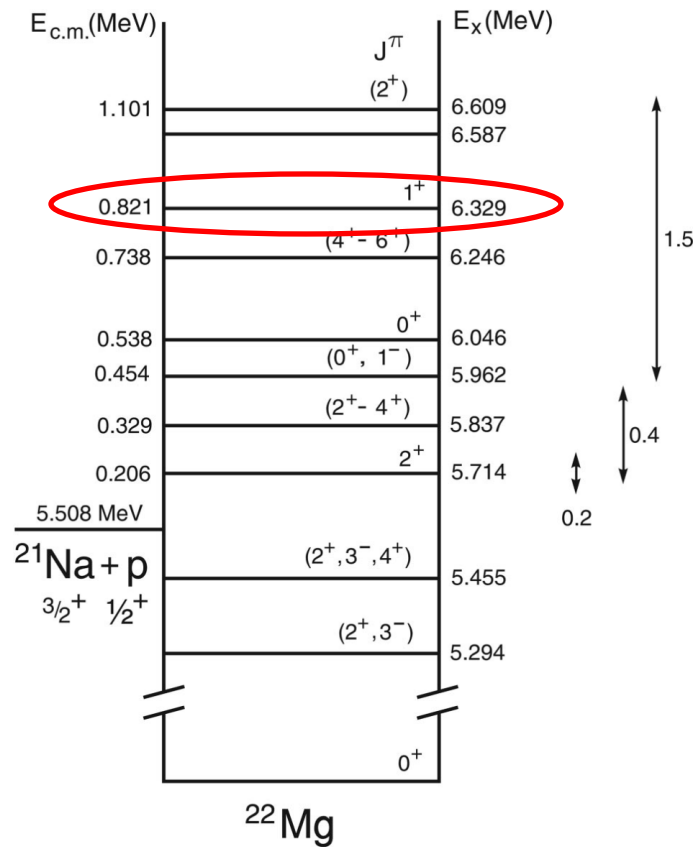
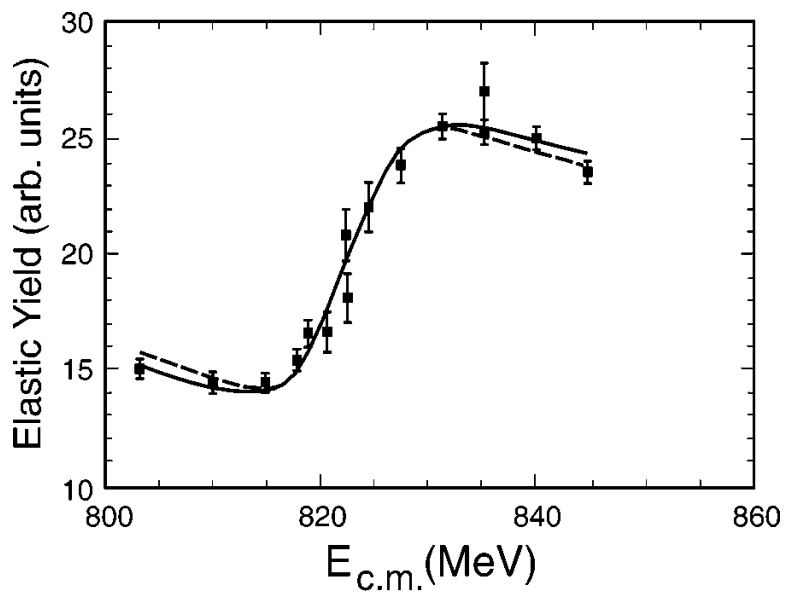
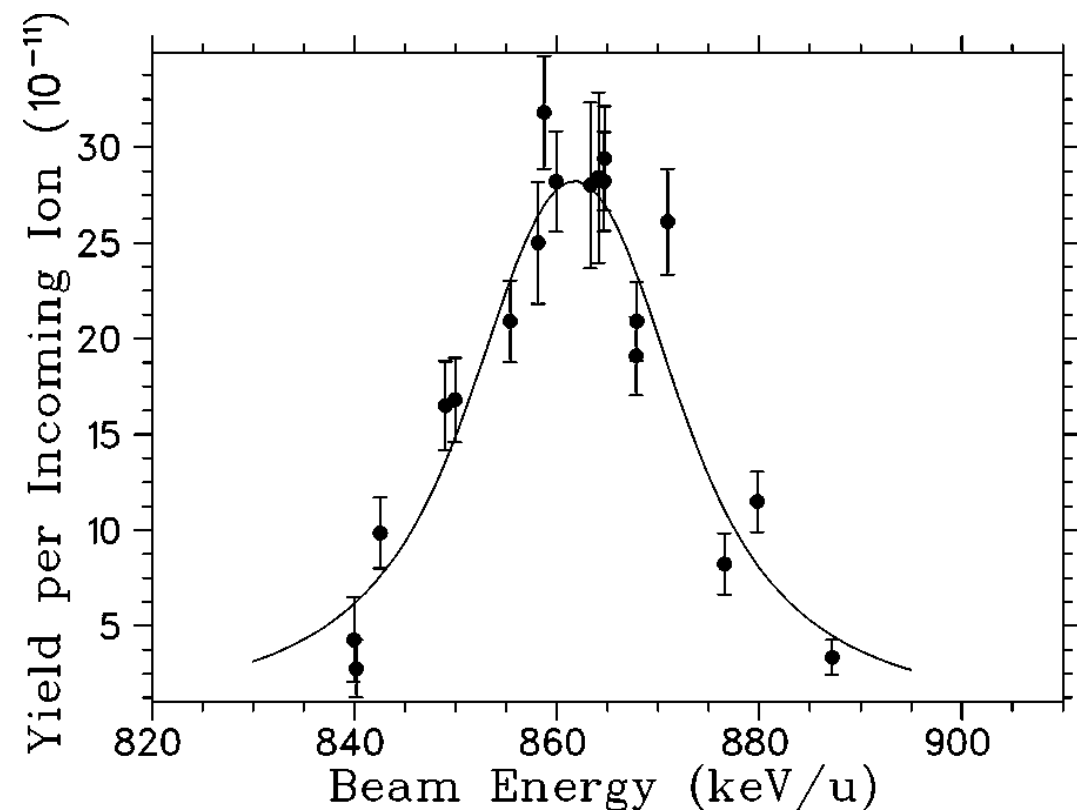

$$\omega\gamma = 556 \pm 77 \text{ keV}$$

Nova Temperature Range

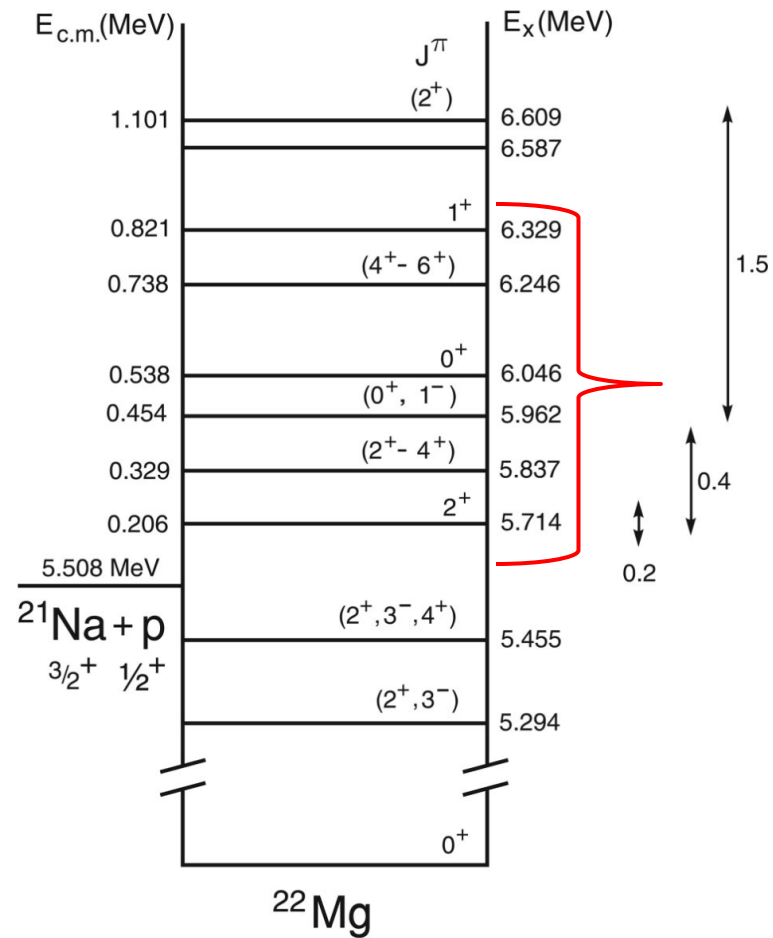
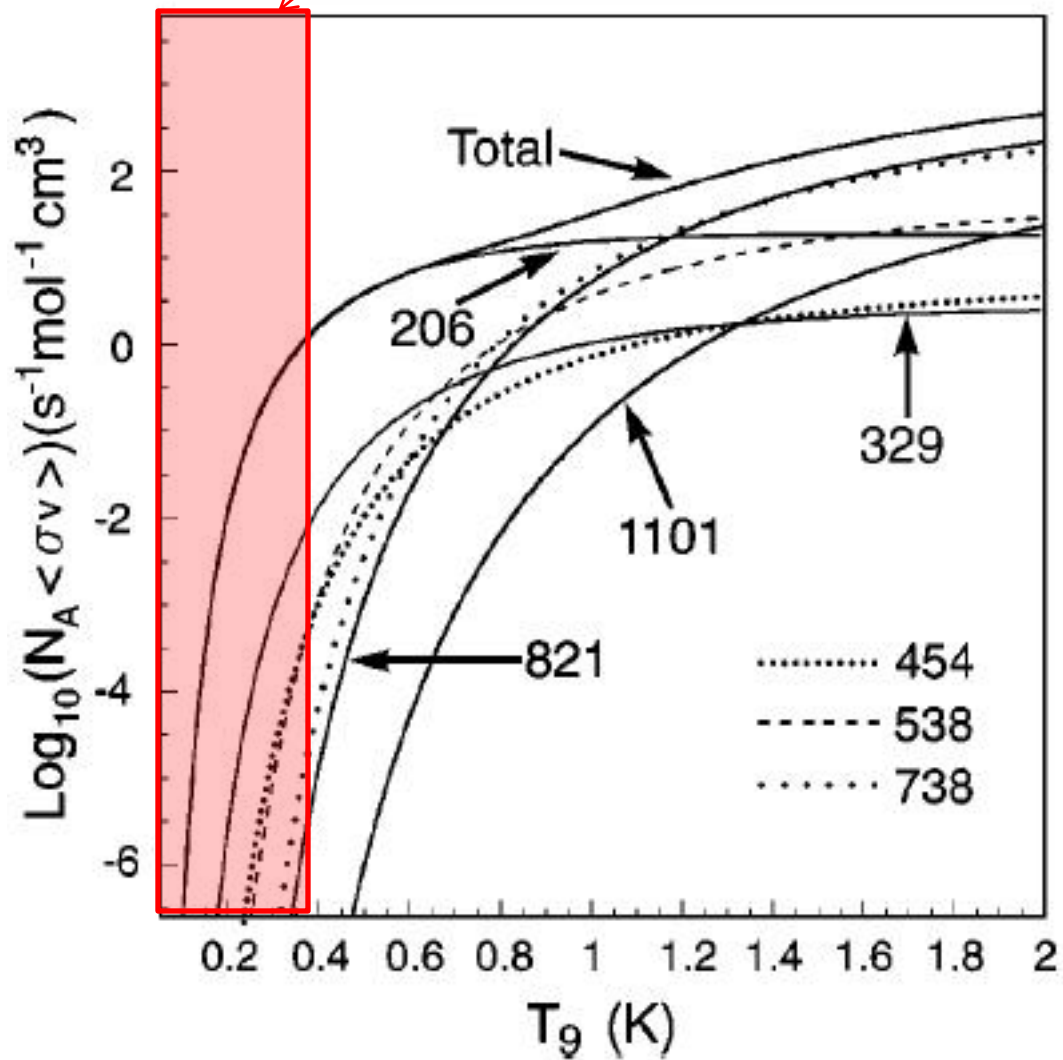

Impact for ^{22}Na production in Oxygen-Neon novae explosions:

- The new experimentally determined rate causes ^{22}Na yield in novae to be reduced by 20% compared to the theoretical rates used previously.
- Because our rate is stronger than the green theoretical prediction on page 29, ^{22}Na gets produced by $^{21}\text{Na}(p,\gamma)^{22}\text{Mg}(\beta)^{22}\text{Na}$ sooner during the thermonuclear runaway on the WD
- Because ^{22}Na is produced earlier in the TNR, it is exposed for a longer time to protons \rightarrow it therefore suffers a higher percentage of destruction from (p,γ) capture reaction leading up to, and at, peak temperatures

Impact for the explosion energy and luminosity of X-ray bursts: Read the PRC article. 😊

Other Implications:

The resonance energy determined for the excited state at $E_x = 5.714$ MeV (the first state above the proton threshold, and most important for novae reaction rate) was determined from the thick target yield curve. It was determined to be about 6 keV *lower* in energy than previously reported in the literature (old value was 212 keV). This result implies:

- A new mass value for ^{22}Mg
- Improved accuracy of the $^{21}\text{Na}(p,\gamma)^{22}\text{Mg}$ reaction rate. Why? Because, the rate is exponentially dependent on the resonance energy: $\propto \exp(-E_r/kT)$